

# Y-TYPE CHECK VALVE ACID-PROOF TYPE ZZYA40

## CHARACTERISTIC:

Diameter	-	15 -200 mm;
Pressure	-	40 bar (flanged may be drilled for 6, 10, 16, 25, bar)
Temperature	-	up to 250°C for acids, bases and other aggressive media; up to 560°C for non-toxic media; (with PTFE sealing up to 200°C);
Medium	-	acids, liquors, water, steam and other non-toxic and non aggressive liquid and gas media, engine fuel.

## VERSIONS:

**type - body material / ends / disc and disc ring / others**

**Example:** ZZYA40 / --- / --- / ---

**Example:** ZZYB40 / S / P / ---

Type - body material	Sign	Ends	Sign	Disc and disc ring	Sign	Others	Sign
X6CrNi18-10 or GX5CrNi19-10	<b>ZZYA40</b>	Standard - flanged	---	Standard	---	-----	---
X2CrNiMo17-12-2 or GX5CrNiMo19-11-2	<b>ZZYB40</b>	Butt weld ends	<b>S</b>	PTFE ring	<b>P</b>		
		Socket weld	<b>SW</b>	NBR ring	<b>N</b>		
		Threaded	<b>G</b>				

## APPLICATION:

The check valves are designed to keep pipeline safe from returning the medium.

**DN 15 - 50**

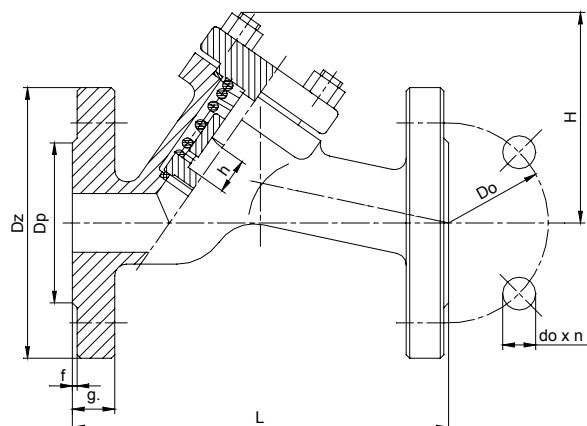

**DN 65 - 200**

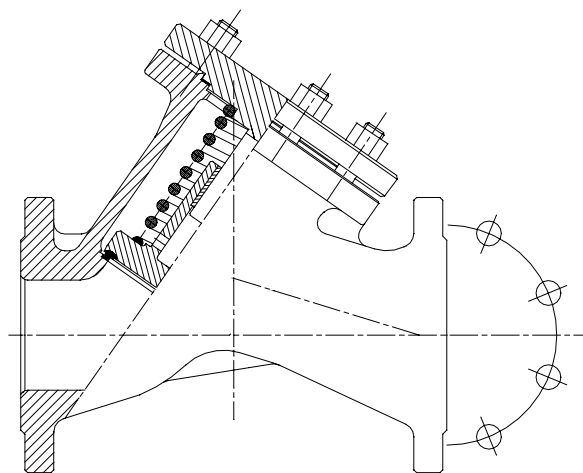

T<sub>MAX</sub> 200°C

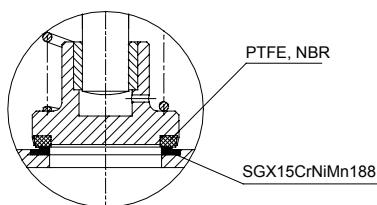

**"G"**

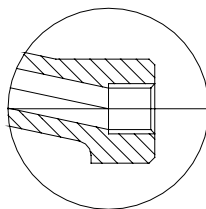

**"SW"**

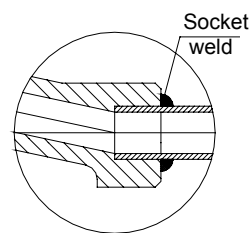

# WK

® FABRYKA ARMATURY PRZEMYSŁOWEJ

**„WAKMET” spółka jawna**

Kaczmarek, Krzywdziński, Wachowski, Wilczyński

Bodzanów 75 48-340 GŁUCHOŁAZY 1

tel. +48(077) 439-40-20, fax +48(077) 439-18-72

e-mail: wakmet@wakmet.com.pl

http: www.wakmet.com.pl

## MATERIALS:

Versions	ZZYA40	ZZYB40	ZZYA40	ZZYB40
Parts	DN 15 - 50		DN 65 - 200	
Body, bonnet	X6CrNiTi18-10 (1.4541)	X2CrNiMo17-12-2 (1.4404)	GX5CrNi19-10 (1.4308)	GX5CrNiMo19-11-2 (1.4408)
Disc	X6CrNiTi18-10 (1.4541)	X2CrNiMo17-12-2 (1.4404)	X6CrNiTi18-10 (1.4541)	X2CrNiMo17-12-2 (1.4404)
Spring	X6CrNiTi18-10 (1.4541)			
Gasket	Grafit			

Special materials on request; modifications reserved.

## DIMENSIONS:

DN	Standard - flanged															With butt weld ends			
	PN 40										PN 16					Dz	Dw	Weight	
	Dz	Dp	Do	do	n	L	g.	f	H	h	Weight	Dz	Dp	Do	do				n
15	95	45	65	14	4	130	16	2	65	10	2,50	95	45	65	14	4	22	17	1,10
20	105	58	75	14	4	150	18	2	65	10	2,90	105	58	75	14	4	28	22	1,40
25	115	68	85	14	4	160	18	2	65	10	3,30	115	68	85	14	4	35	28,5	1,70
32	140	78	100	18	4	180	18	2	85	15	6,80	140	78	100	18	4	44	37	3,60
40	150	88	110	18	4	200	18	3	95	17	9,00	150	88	110	18	4	50	43	4,70
50	165	102	125	18	4	230	20	3	110	21	10,50	165	102	125	18	4	62	54	6,10
65	185	122	145	18	8	290	22	3	155	22	17,50	185	122	145	18	4	77	69	12,70
80	200	138	160	18	8	310	24	3	170	26	27,00	200	138	160	18	8	91	81	18,50
100	235	162	190	22	8	350	24	3	195	32	41,00	220	158	180	18	8	117	104	36,00
125	270	188	220	26	8	400	26	3	200	40	54,00	250	184	210	18	8	144	130,5	49,00
150	300	218	250	26	8	480	28	3	225	44	90,00	285	212	240	22	8	172	156,5	76,00
200	375	285	320	30	12	600	34	3	270	60	150,00	340	268	295	22	12	223	204,5	140,00

Dimensions in mm; modifications reserved.

## TECHNICAL DATA:

Body material	Medium	PN	Maximal working pressure at working temperature																
			20°C	100°C	150°C	200°C	250°C	300°C	350°C	400°C	450°C	480°C	500°C	510°C	520°C	530°C	540°C	550°C	
X6CrNiTi18-10 (1.4541)	aggressive media	40	40,0	39,6	37,3	35,4	33,7	-	-	-	-	-	-	-	-	-	-	-	-
GX5CrNi19-10 (1.4308)		40	40,0	35,2	30,5	27,1	23,8	-	-	-	-	-	-	-	-	-	-	-	-
X6CrNiTi18-10 (1.4541)	non aggressive media	40	40,0	39,6	37,3	35,4	33,7	31,8	30,6	29,7	29,0	28,7	28,3	28,0	27,8	27,5	27,2	27,0	-
GX5CrNi19-10 (1.4308)		40	40,0	35,2	30,5	27,1	23,8	22,4	20,9	19,5	18,1	16,7	15,2	-	-	-	-	-	-
X2CrNiMo17-12-2 (1.4404)	Aggressive media	40	40,0	40,0	39,1	37,1	36,7	-	-	-	-	-	-	-	-	-	-	-	-
GX5CrNiMo19-11-2 (1.4408)		40	40,0	32,4	29,1	25,7	23,8	-	-	-	-	-	-	-	-	-	-	-	-
X2CrNiMo17-12-2 (1.4404)	Non Aggressive media	40	40,0	40,0	39,1	37,1	36,7	34,5	33,1	32,1	31,3	30,7	30,5	30,4	30,3	30,3	30,3	30,2	-
GX5CrNiMo19-11-2 (1.4408)		40	40,0	32,4	29,1	25,7	23,8	21,9	20,9	20,0	19,4	19,2	19,1	-	-	-	-	-	-

## MOUNTING AND OPERATING:

*MOUNTING OF VALVE AND ITS SERVICE SHOULD BE MADE BY ORGANIZATION THAT HAS RIGHTS TO MAKE THAT KIND OF WORKS. THE PERSONEL OF THOSE ORGANIZATIONS IS SUPPOSED TO BE QUALIFIED.*

Before valve will be installed the pipeline must be clean from any mechanical impurities. The compatibility of critical parameters of flow must be checked with the parameters of valve. Stop globe valve can be mounted to a pipe-line in any position. The direction of flow should only comply with the arrow marked on the body. The valve should be operate strictly with its assign. To make valve unfailing you must observe the following suggestions:

- medium flowing through the valve is supposed to be clean out of any mechanical impurities.
- the valve must be protected from any mechanical damages during his work.
- parameters should be the same as on the valve.