

# SCREW-DOWN-NON- RETURN VALVE - ANGULAR TYPE 333

## CHARACTERISTIC:

Diameter	-	15 -250 mm;
Pressure	-	40 bar (flanges may be drilled for PN 6, 10, 16, 25 bar);
Temperature	-	up to 530°C (with PTFE sealing up to $\leq 200^{\circ}\text{C}$ );
Medium	-	water, steam and other non-toxic, non aggressive liquid and gas media and engine fuel, sea water.

## VERSIONS:

**type / ends / body material / disc and disc ring / others**

Example: 333 / --- / --- / --- / ---

Example: 333 / S / U / P / WM

Ends	Sign	Body material	Sign	Disc and disc ring	Sign	Others	Sign
Standard - flanged	---	(P250GH) C 22.8 or GP240GH	---	Standard	---		
Butt weld ends	S	16Mo3 or G20Mo5	U	PTFE ring	P	Sea version	WM
Socket weld	SW			NBR ring	N		
Threaded	G			STELLIT ring	L		

## APPLICATION:

The valves are designed to keep pipeline safe from returning the medium. Screw-down-non-return valve can be used as a stop globe valve to open and stop the flow. The valve is not supposed to be used as a regulating device.

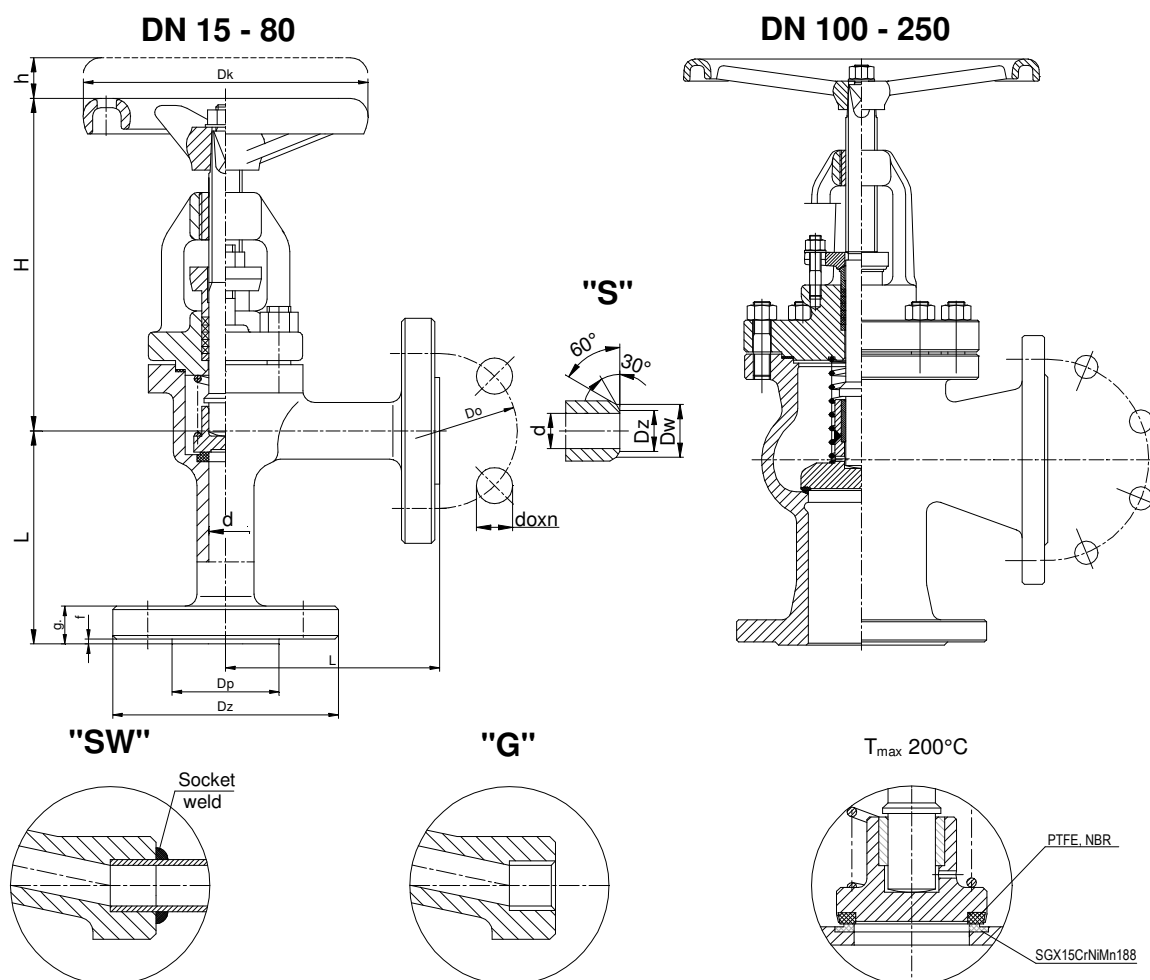

# WK



**FABRYKA ARMATURY PRZEMYSŁOWEJ**

**WAKMET Sp. z o.o.**

Bodzanów 75 48-340 GŁUCHOŁAZY  
tel. +48 77 439-40-20, fax +48 77 439-18-72  
[wakmet@wakmet.com.pl](mailto:wakmet@wakmet.com.pl) [www.wakmet.com.pl](http://www.wakmet.com.pl)

## MATERIALS:

Versions Parts	Standard T <sub>MAX</sub> 450°C	U T <sub>MAX</sub> 530°C	A T <sub>MAX</sub> 560°C	WM T <sub>MAX</sub> 450°C	Other version -
Body DN15-50	(P250GH) C22.8 (1.0460)	16Mo3 (1.5415)	13CrMo4-5 (1.7335)	(P250GH) C22.8 (1.0460)	(P250GH) C22.8, 16Mo3, 13CrMo4-5
Bonnet DN15-50		13CrMo4-5 (1.7335)			
Body DN 65-300	GP240GH (1.0619)	G17CrMo5-5 (1.7357)	G17CrMo5-5 (1.7357)	GP240GH (1.0619)	GP240GH, G20Mo5, G17CrMo5-5
Bonnet DN65-300					
Seat ring DN15-25	X17CrNi16-2				Stellit or CW306G
Seat ring	G 18 8 Mn(1.4370)				
Disc DN 15-50	X30Cr13 (1.4028)	X30Cr13(1.4028)	13CrMo4-5 (1.7335)	X17CrNi16-2 (1.4057)	CW306G
Disc DN 65-300	P250GH (1.0460)	P250GH (1.0460)	13CrMo4-5 (1.7335)	P250GH (1.0460)	CW306G
Disc ring	G 18 8 Mn (1.4370)				Stellit lub CW306G or PTFE or NBR
Stem	X20Cr13 (1.4021)	X17CrNi16-2 (1.4057)	X39CrMo17-1 (1.4122)	X17CrNi16-2 (1.4057)	BT9 or CW306G
Spring	51CrV4 (1.2241)				
Packing rings, gasket	Graphite				
Wheel	Cast iron				

Special materials on request; modifications reserved.

## DIMENSIONS:

DN	Standard - flanged																		With butt weld ends		
	PN 40												PN 16						Dz	Dw	Weight
	Dz	Dp	Do	do	n	L	g.	f	H	h	Dk	Weight	Dz	Dp	Do	do	n				
15	95	45	65	14	4	90	16	2	153	15	120	3,90	95	45	65	14	4	22	17	2,30	
20	105	58	75	14	4	95	18	2	153	15	120	4,40	105	58	75	14	4	28	22	2,20	
25	115	68	85	14	4	100	18	2	153	15	120	4,90	115	68	85	14	4	35	28,5	2,30	
32	140	78	100	18	4	105	18	2	240	17	160	8,50	140	78	100	18	4	44	37	4,70	
40	150	88	110	18	4	115	18	3	250	22	160	9,10	150	88	110	18	4	50	43	4,80	
50	165	102	125	18	4	125	20	3	255	26	160	12,40	165	102	125	18	4	62	54	6,70	
65	185	122	145	18	8	145	22	3	290	30	200	24,50	185	122	145	18	4	77	69	17,20	
80	200	138	160	18	8	155	24	3	320	36	250	32,80	200	138	160	18	8	91	81	23,90	
100	235	162	190	22	8	175	24	3	360	50	320	55,50	220	158	180	18	8	117	104	43,80	
125	270	188	220	26	8	200	26	3	390	58	280	67,00	250	184	210	18	8	144	130,5	50,80	
150	300	218	250	26	8	225	28	3	440	70	320	88,50	285	212	240	22	8	172	156,5	68,60	
200	375	285	320	30	12	275	34	3	515	92	400	150,00	340	268	295	22	12	223	204,5	114,20	
250	450	345	385	33	12	325	38	3	590	130	400	245,00	405	320	355	26	12	278	256,5	196,60	

Dimensions in mm; modifications reserved.

## TECHNICAL DATA:

Body material	PN	Maximal working pressure at working temperature																
		20°C	100°C	150°C	200°C	250°C	300°C	350°C	400°C	450°C	480°C	500°C	510°C	520°C	530°C	540°C	550°C	560°C
(P250GH)C 22.8 (1.0460)	40	40,0	40,0	40,0	36,2	32,4	28,6	24,8	20,9	13,1	-	-	-	-	-	-	-	-
16Mo3 (1.5415)	40	40,0	40,0	40,0	40,0	39,0	34,3	32,4	30,5	29,5	22,4	17,7	14,5	11,2	9,0	-	-	-
GP240GH (1.0619)	40	40,0	31,6	28,9	26,3	24,1	20,3	25,7	19,5	12,5	-	-	-	-	-	-	-	-
G20Mo5 (1.5419)	40	40,0	33,2	30,9	28,6	26,7	24,8	23,3	22,5	21,8	16,4	12,8	-	-	-	-	-	-

Permissible working pressure directed under the disc when the valve is closed.

DN [mm]	125	150	200	250
P <sub>max</sub> [bar]	33	21	14	10

## MOUNTING AND OPERATING:

*The valve can only be mounted and operated by skilled, properly trained and qualified personnel. Incorrect assembly or operation of the valve may have substantial impact on the entire system such as fluid leakage, reduction in system's function etc.*

Before a valve is installed the pipeline must be clean from any mechanical impurities. The compatibility of critical parameters of the flow must be checked with the parameters of the valve. Stop globe valve can be mounted to a pipe-line in any position. The direction of flow should only comply with the arrow marked on the body. The valve should be operated strictly with its assign. In order to provide valve's reliability the following suggestions must be observed:

- medium flowing through the valve is supposed to be clean out of any mechanical impurities;
- the valve must be protected from any mechanical damages during its work;
- nominal parameters marked on the valve must be observed.