

STOP GLOBE VALVE TYPE 669

CHARACTERISTIC:

Diameter	-	15 -100 mm;
Pressure	-	500 bar;
Temperature	-	up to 670°C;
Medium	-	water, steam and other non-toxic, non aggressive liquid and gas media.

VERSIONS:

type / ends / body material / disc and disc ring / drive type

Example: 669 / --- / --- / --- / ---

Example: 666 / SW / U / L / ---

Ends	Sign	Body material	Sign	Disc and disc ring	Sign	Drive type	Sign
Standard-butt weld ends	---	(P250GH) C 22.8	---	Standard	---	Hand wheel	---
Socket weld	SW	16Mo3	U	Stellit ring	L	AUMA drive	NA
		13CrMo4-5	A			NWA drive	NW
		11CrMo9-10	B			MODACT drive	NM
		14MoV6-3	C			Pneumatic drive	NP
		X10CrMoVNb9-1	E				

APPLICATION:

Stop globe valve (659) is designed to open and stop the flow. The valve is not supposed to be used as a regulating device. For regulation the version (684) with throttling plug should be applied.

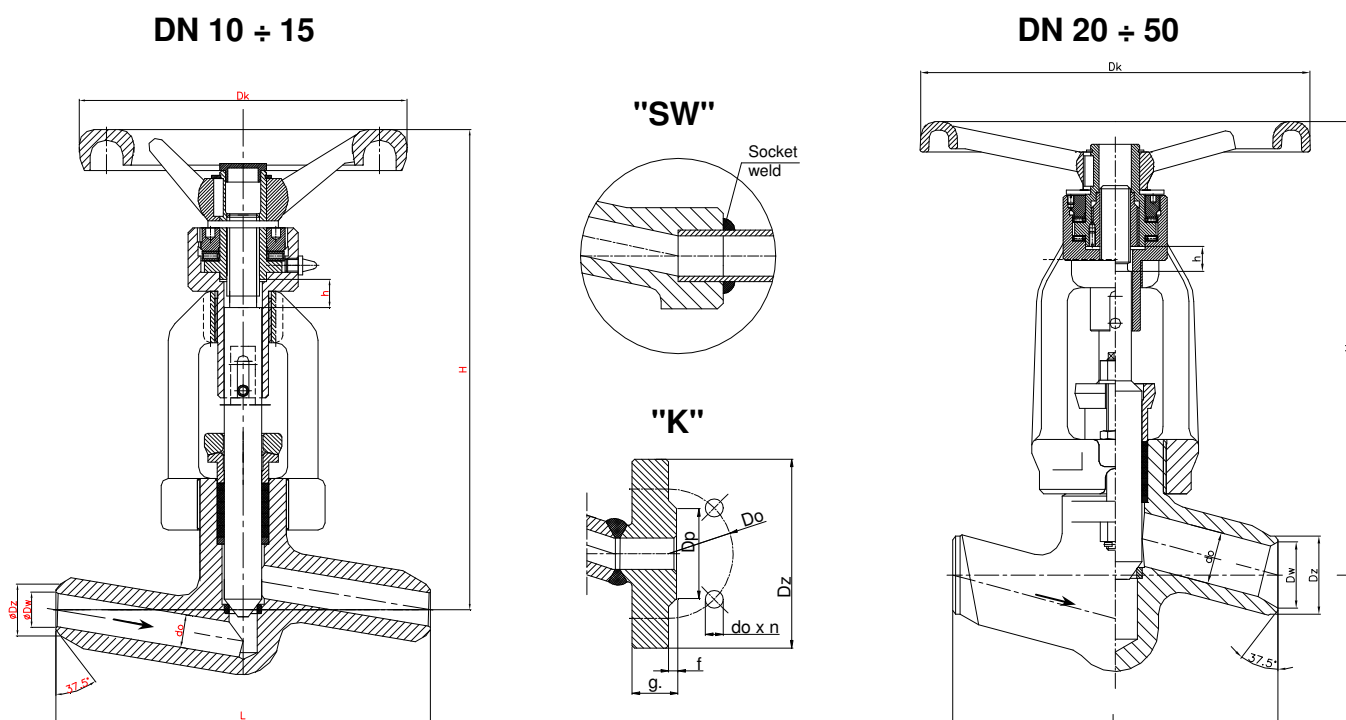

FABRYKA ARMATURY PRZEMYSŁOWEJ

WAKMET Sp. z o.o.

Bodzanów 75 48-340 GŁUCHOŁAZY
tel. +48 77 439-40-20, fax +48 77 439-18-72
wakmet@wakmet.com.pl www.wakmet.com.pl

MATERIALS:

Versions	Standard	U	A	B	C
Parts	T _{MAX} 450°C	T _{MAX} 530°C	T _{MAX} 560°C	T _{MAX} 600°C	T _{MAX} 570°C
Body	(P250GH) C22.8 (1.0460)	16Mo3 (1.5415)	13CrMo4-5 (1.7335)	11CrMo9-10 (1.7383)	14MoV6-3 (1.7715)
Bonnet	DN 15-25 13CrMo4-5 (1.7335)		DN 32-100 G17CrMo5-5 (1.7357)		
Stem DN 15-65	X39CrNi17-1 (1.4122), X22CrMoV12-1 (1.4923)				
Disc DN 80-100	11CrMo9-10 (1.7383)	11CrMo9-10 (1.7383)	11CrMo9-10 (1.7383)	11CrMo9-10 (1.7383)	11CrMo9-10 (1.7383)
Seat ring	BT9; Stellite				
Upper stem	X17CrNi16-2 (1.4057), X39CrNi17-1 (1.4122)				
Wheel	Cast iron				

Special materials on request; modifications reserved.

DIMENSIONS:

Standard – butt weld ends / SW						H	h	Dk
DN	d	Dz	Dw	L	Weight			
10	10	20	9,5	160	9,00	205	12	200
15	14	28	16					
20	20	35	21,5	160	9,00	266	19	280
25	24	44	26					
32	30	56	32,5	300	30,00 40,00 70,00	418	23	500
40	38	65	43					
50	44	83	49,5					
65	62	91	59	340	-	714	45	GNR 700
80	76	117	76,5	380*	-	637	36	GNR 500
100	92	155	106	430*	-	720	50	GNR 500

Dimensions in mm; modifications reserved.

* - only for butt weld ends not for socket weld

TECHNICAL DATA:

Body material	PN	Maximal working pressure at working temperature																
		20°C	100°C	150°C	200°C	250°C	300°C	350°C	400°C	450°C	500°C	510°C	520°C	530°C	540°C	560°C	570°C	600°C
bar																		
C22.8 (1.0460)	500	500,0	500,0	500,0	453,0	405,0	358,0	310,0	262,0	165,0	-	-	-	-	-	-	-	-
16Mo3 (1.5415)	500	500,0	500,0	500,0	500,0	489,0	429,0	405,0	382,0	369,0	222,0	176,0	141,0	112,0	-	-	-	-
13CrMo4-5 (1.7335)	500	500,0	500,0	500,0	500,0	500,0	500,0	477,0	453,0	429,0	327,0	276,0	224,0	186,0	146,0	95,0	-	-
14MoV6-3 (1.7715)	500	500,0	500,0	500,0	500,0	500,0	500,0	500,0	498,0	484,0	480,0	460,0	355,0	312,0	269,0	205,0	174,0	-
11CrMo9-10 (1.7383)	500	500,0	500,0	500,0	500,0	489,0	465,0	441,0	417,0	393,0	379,0	322,0	246,0	215,0	186,0	138,0	122,0	81,0
Body material	PN	Maximal working pressure at working temperature																
		20°C	530°C	540°C	550°C	560°C	570°C	580°C	590°C	600°C	610°C	620°C	630°C	640°C	650°C	660°C	670°C	
bar																		
X10CrMoVNB9-1 (1.4903)	500	500	479	436	395	357	319	286	252	224	198	174	155	133	117	100	86	

MOUNTING AND OPERATING:

The valve can only be mounted and operated by skilled, properly trained and qualified personnel. Incorrect assembly or operation of the valve may have substantial impact on the entire system such as fluid leakage, reduction in system's function etc.

Before a valve is installed the pipeline must be clean from any mechanical impurities. The compatibility of critical parameters of the flow must be checked with the parameters of the valve. Stop globe valve can be mounted to a pipe-line in any position. The direction of flow should only comply with the arrow marked on the body. The valve should be operated strictly with its assign. In order to provide valve's reliability the following suggestions must be observed:

- medium flowing through the valve is supposed to be clean out of any mechanical impurities;
- the valve must be protected from any mechanical damages during its work;
- nominal parameters marked on the valve must be observed.